

NOTES :-
 1 ALL DIMENTIONS ARE IN MM
 2 REMOVE ALL BURS & SHARP EDGES.

THIS DRAWING IS THE PROPERTY OF **INDRAPRASTHA GAS LIMITED**. UNAUTHORISED DISCLOSURE OF ITS CONTENTS AND MANUFACTURE OR SUPPLY OF THE PRODUCT TO ANYONE IS PROHIBITED.

MATERIAL: **C.I.**

TREATMENT:

J Bush for DR Comp. Pulley

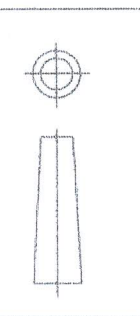

REV. No	REVISION	BY	DATE	ANGULAR	± 1°	OPEN TOLERANCE	± 0.1	> 30-120	± 0.3	DRW. BY	NAME	SIGN.	DATE	DRAWING No. ICL/MIS-108	SCALE
				> 6-30	± 0.2	> 120-315	± 0.5			CHKD BY				INDRAPRASTHA GAS LTD.	SHEET
										APP'D BY				NEW DELHI	1 OF 1
										QTY.	01 Nos.				

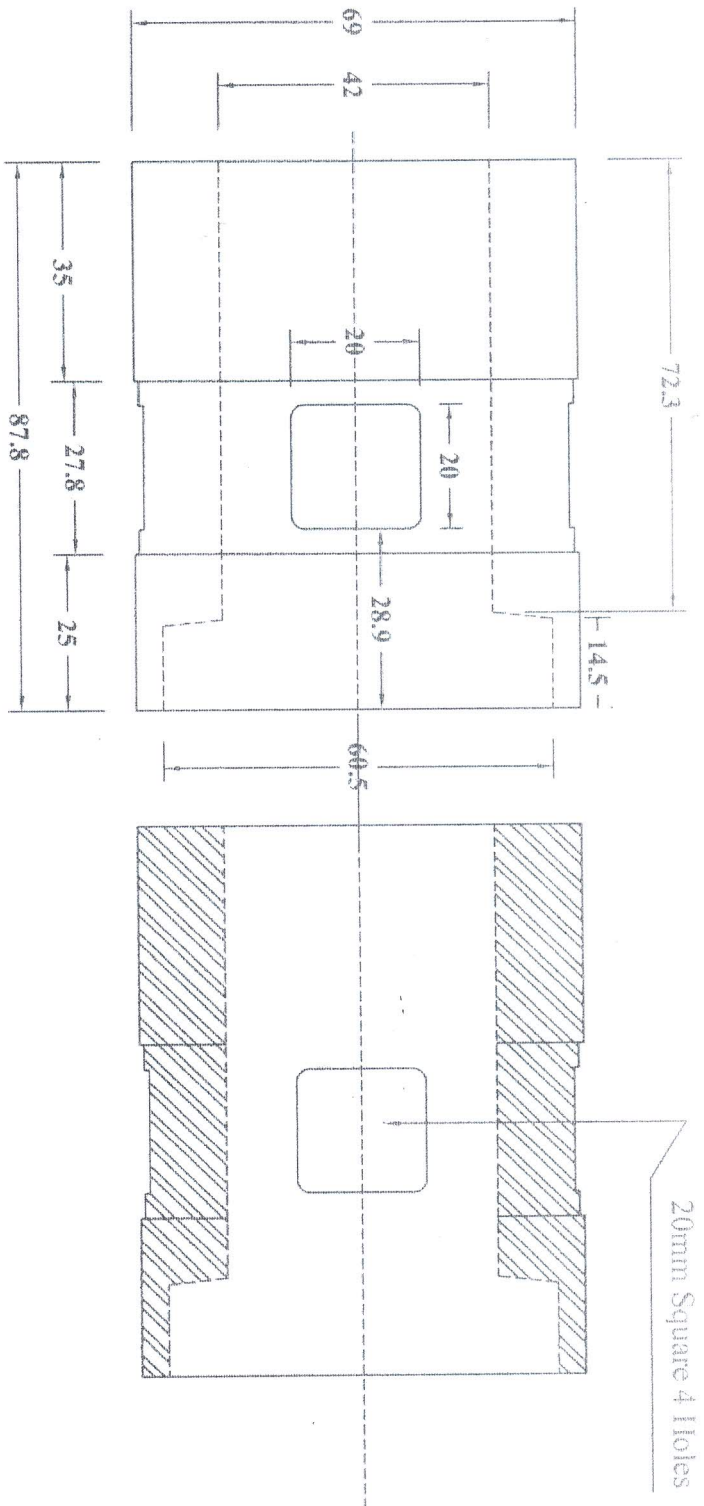

NOTES :-
 1. ALL DIMENSIONS ARE IN MM.
 2. REMOVE ALL BURRS & SHARP EDGES.

THIS DRAWING IS THE PROPERTY OF **INDRAPRASTHA GAS LIMITED**. UNAUTHORISED DISCLOSURE OF ITS CONTENTS AND MANUFACTURE OR SUPPLY OF THE PRODUCT TO ANYONE IS PROHIBITED.

MATERIAL	C STEEL
TREATMENT	

Valve Retainer Arrangement

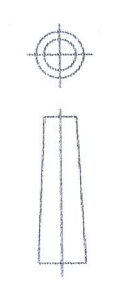

OPEN TOLERANCE	
0.5-6	± 0.1
> 30-120	± 0.3
> 6-30	± 0.2
ANGULAR	± 1°

DRN/By	NAME	SIGN.	DATE
CHD/By			
APPD/By			

SCALE: N.T.S.

REV.No.	REVISION	BY	DATE	QTY.	01 Nos.

DRAWING No. IGL/MIS-115
 INDRAPRASTHA GAS LTD.
 NEW DELHI

SHEET 1 OF 1

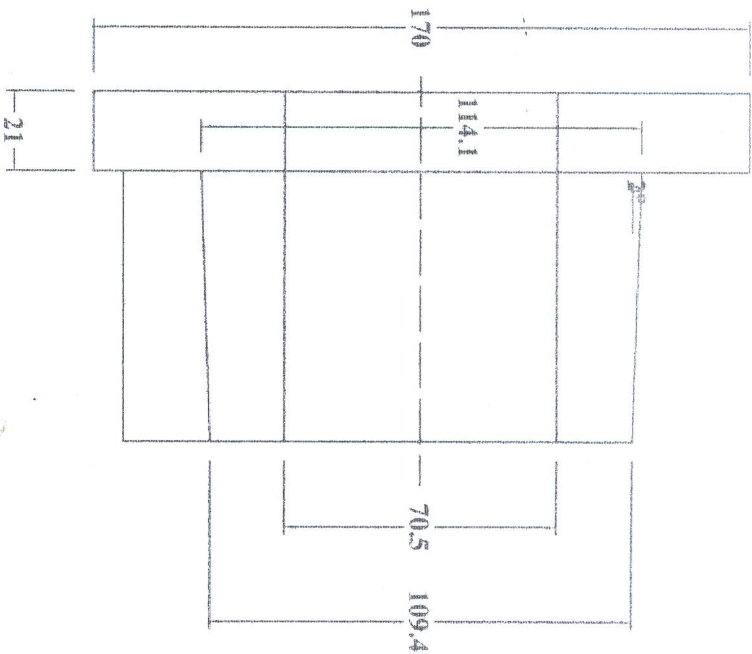
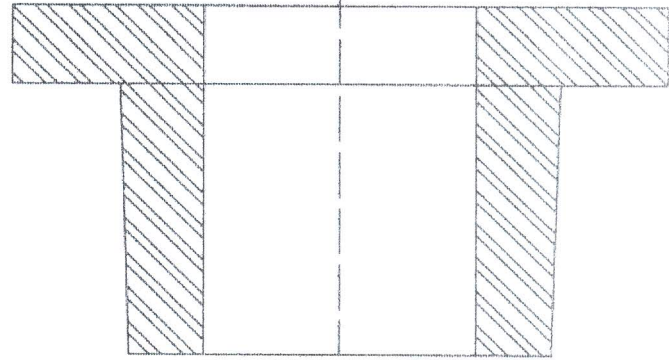
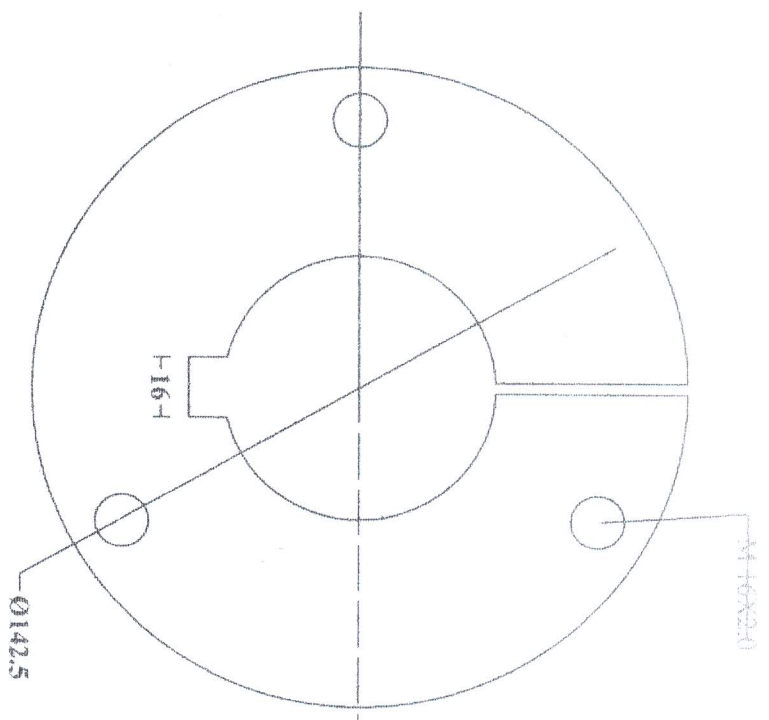

NOTES :-

- 1. ALL DIMENSIONS ARE IN MM.
- 2. REMOVE ALL BEERS & SHARP EDGES

THIS DRAWING IS THE PROPERTY OF **INDRAPRASHTA GAS LIMITED** UNAUTHORIZED DISCLOSURE OF ITS CONTENTS AND MANUFACTURE OR SUPPLY OF THE PRODUCT TO ANYONE IS PROHIBITED

MATERIAL

C.I.

TREATMENT

J bush for Waukesha Engine

OPEN TOLERANCE

0.5-6	± 0.1	> 10-120	± 0.3
> 6-30	± 0.2	> 120-315	± 0.5
ANGULAR	± 1°		

NAME SIGN. DATE

DRN BY: *Kajal Kumar*
 CHD BY: *VSK*
 APPD BY: *VSK*
 QTY: 01 Nos. DATE: *1/6/15*

DRAWING No. IGL/MIS-107

INDRAPRASHTA GAS LTD.
 NEW DELHI

SCALE
 N.T.S.



SHEET 1 OF 1

REV. No.	REVISION	BY	DATE
----------	----------	----	------

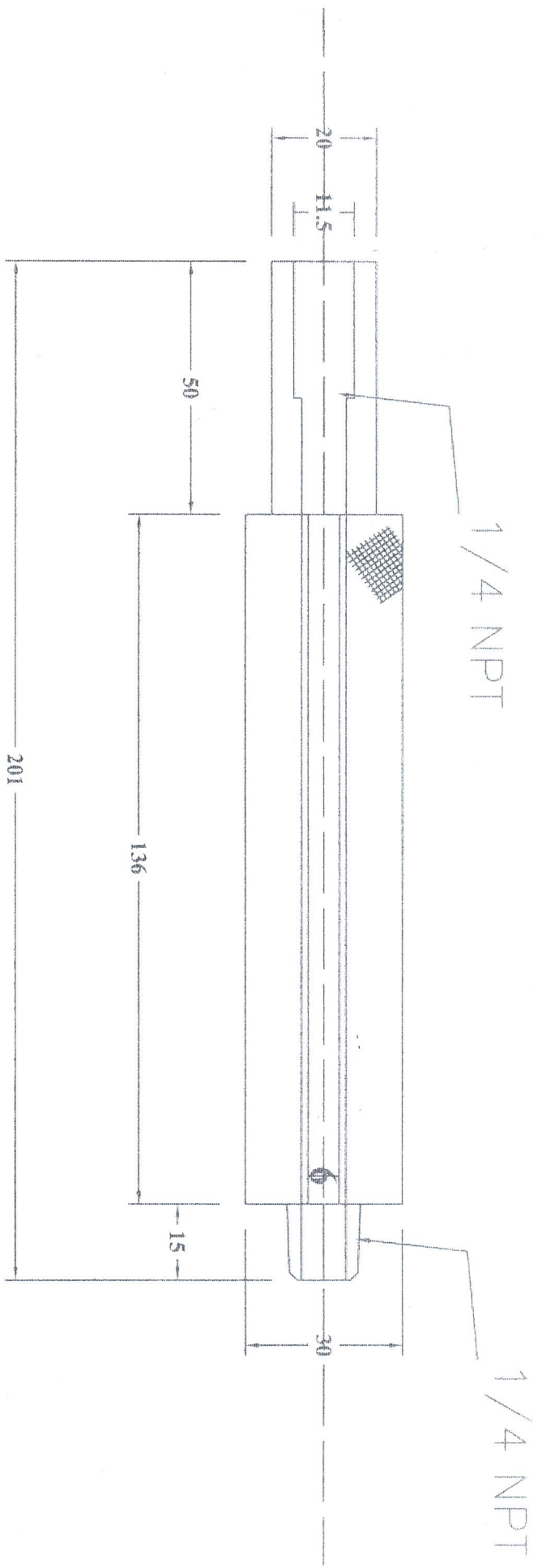

NOTES :-
 1. ALL DIMENSIONS ARE IN MM
 2. REMOVE ALL BURRS & SHARP EDGES

THIS DRAWING IS THE PROPERTY OF **INDRAPASTHA GAS LIMITED**. UNAUTHORISED DISCLOSURE OF ITS CONTENTS AND MANUFACTURE OR SUPPLY OF THE PRODUCT TO ANYONE IS PROHIBITED

MATERIAL	S. STEEL
TREATMENT	

CRADLE HANDLE (Galelio)

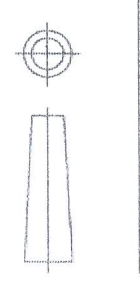

OPEN TOLERANCE			
0.5-6	± 0.1	> 30-120	± 0.3
> 6-30	± 0.2	> 120-315	± 0.5
ANGULAR	± 1°		

DRAWING No.	IGL/MIS-110
INDRAPASTHA GAS LTD. NEW DELHI	

SCALE
 NTS.

REV. No	REVISION	BY	DATE	QTY	01 Nos.

DRAWN BY	DRN/By	NAME	SIGN.	DATE
CDD/By		S. Kumar		1/11/15
APP/By				

SHEET
 1 OF 1

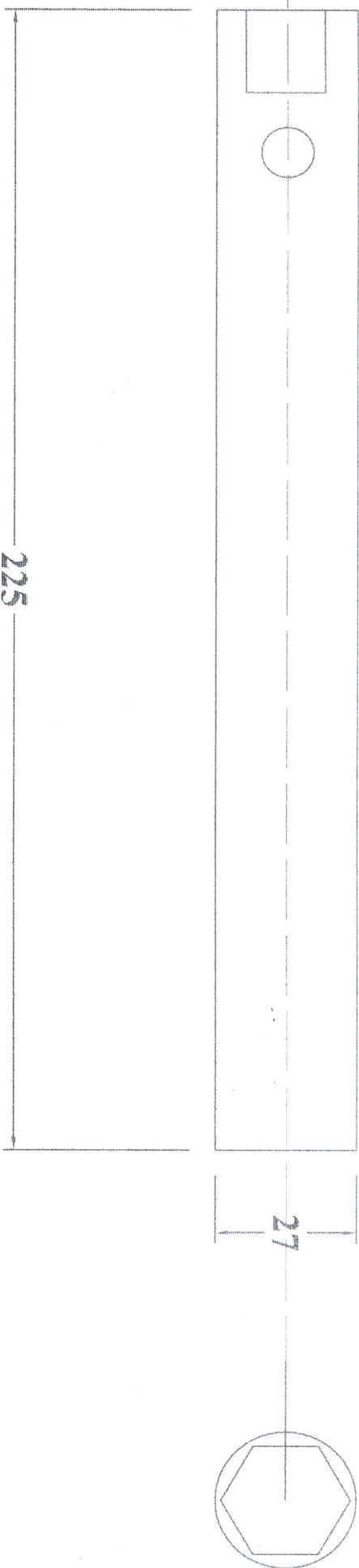

NOTES :-
 1. ALL DIMENSIONS ARE IN MM.
 2. REMOVE ALL BURRS & SHARP EDGES.

THIS DRAWING IS THE PROPERTY OF **INDRAPRASTHA GAS LIMITED**. UNAUTHORIZED DISCLOSURE OF ITS CONTENTS AND MANUFACTURE OR SUPPLY OF THE PRODUCT TO ANYONE IS PROHIBITED.

MATERIAL
 MS

TREATMENT



DRN/By	NAME	SIGN.	DATE
CHD/By	Raj Kumar	[Signature]	1/4/15
APPD/By			

SPARK PLUG REMOVING ARRANGEMENT (Waukesha)

SCALE
 NTS.

OPEN TOLERANCE

0.5-6	± 0.1	> 30-120	± 0.3
> 6-30	± 0.2	> 120-315	± 0.5

REV. No.	REVISION	BY	DATE	ANGULAR	± 1°	QTY.	01 Nos.

DRAWING No. IGI/MIS-112
 INDRAPRASTHA GAS LTD.
 NEW DELHI

SHEET
 1 OF 1

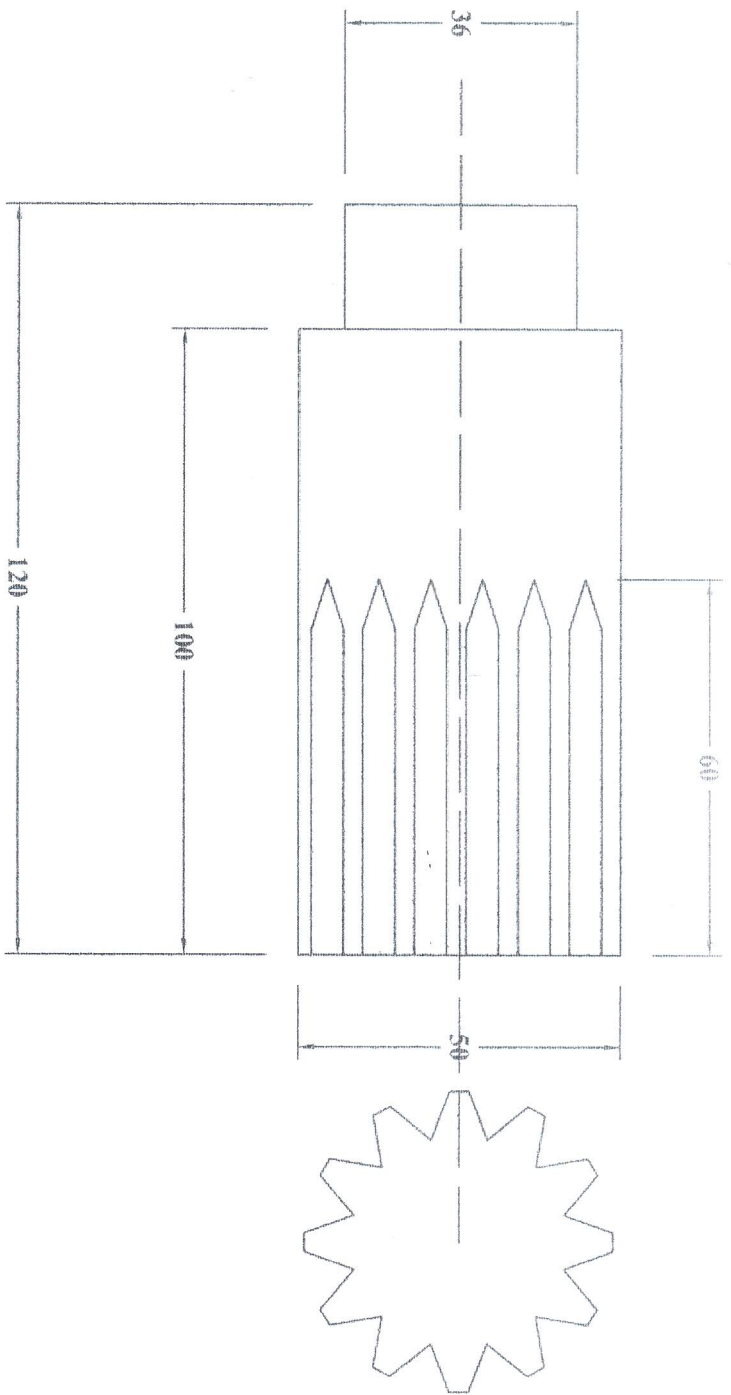

NOTES :-
 1. ALL DIMENSIONS ARE IN MM.
 2. REMOVE ALL BURRS & SHARP EDGES.

THIS DRAWING IS THE PROPERTY OF **INDRAPRASHTA GAS LIMITED**. UNAUTHORIZED DISCLOSURE OF ITS CONTENTS AND MANUFACTURE OR SUPPLY OF THE PRODUCT TO ANYONE IS PROHIBITED.

MATERIAL: **EN-8**
 TREATMENT:

BARRING ARRANGEMENT FOR CAT ENGINE

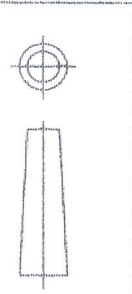

OPEN TOLERANCE		DRAWN BY: <i>DRN/By</i>		NAME:		SIGN:		DATE:	
0.5-6	± 0.1	> 30-120	± 0.3	<i>DRN/By</i>	<i>DRN/By</i>	<i>DRN/By</i>	<i>DRN/By</i>	<i>DRN/By</i>	<i>DRN/By</i>
> 6-30	± 0.2	> 120-315	± 0.5	<i>CHKD BY</i>	<i>CHKD BY</i>	<i>CHKD BY</i>	<i>CHKD BY</i>	<i>CHKD BY</i>	<i>CHKD BY</i>
ANGULAR	± 1°			<i>APP'D BY</i>	<i>APP'D BY</i>	<i>APP'D BY</i>	<i>APP'D BY</i>	<i>APP'D BY</i>	<i>APP'D BY</i>
REV. No.	REVISION	BY	DATE	QTY.	01 Nos.	DRAWING No. IGL/MIS-113			
						INDRAPRASHTA GAS LTD.			
						NEW DELHI			
						SCALE: NTS.			
						SHEET 1 OF 1			

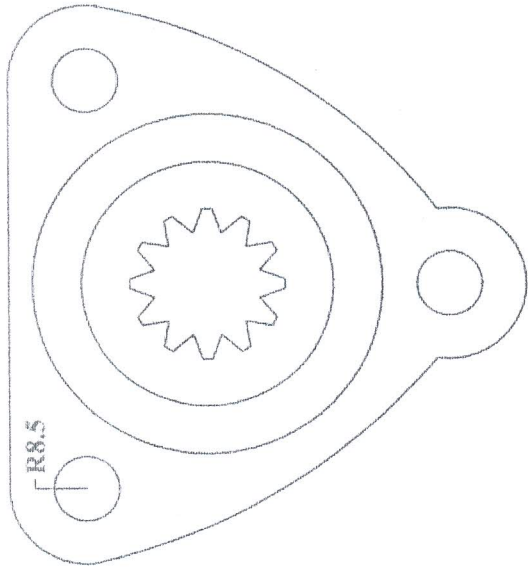
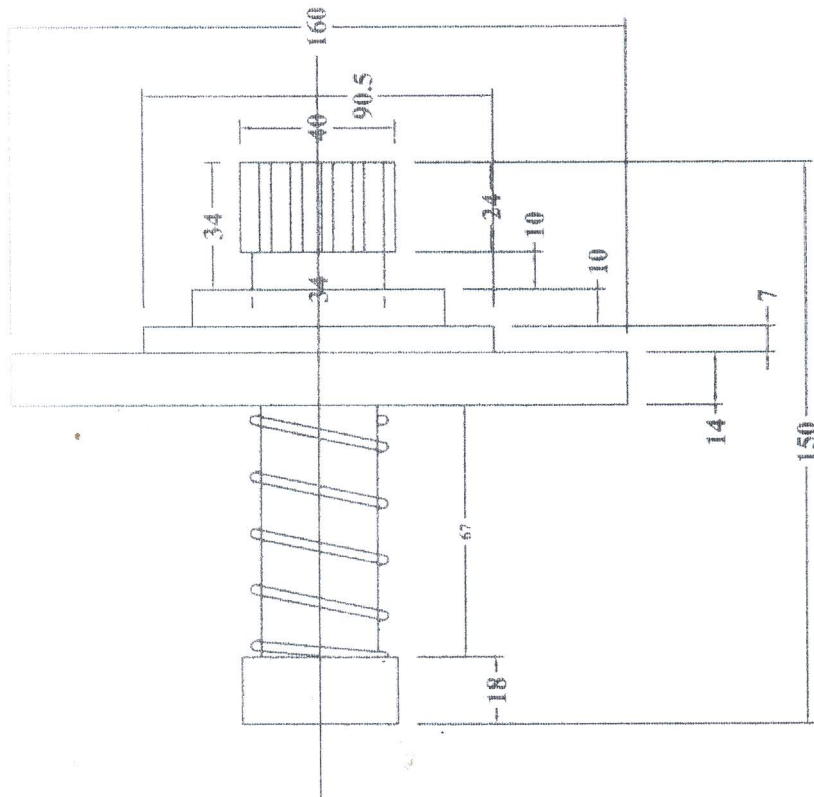

NOTES :-
 1. ALL DIMENSIONS ARE IN MM
 2. REMOVE ALL BURRS & SHARP EDGES

THIS DRAWING IS THE PROPERTY OF **INDRAPRASHTHA GAS LIMITED**. UNAUTHORISED DISCLOSURE OF ITS CONTENTS AND MANUFACTURE OR SUPPLY OF THE PRODUCT TO ANYONE IS PROHIBITED.

MATERIAL
 MS & CI

BARRING ARRANGEMENT FOR WAUKESHA



REV.No	REVISION	BY	DATE	QTY.	01 Nos.

DRAWING No IGL/MIS-114
 INDRAPRASHTHA GAS LTD.
 NEW DELHI

SCALE
 NTS.
 SHEET
 1 OF 1

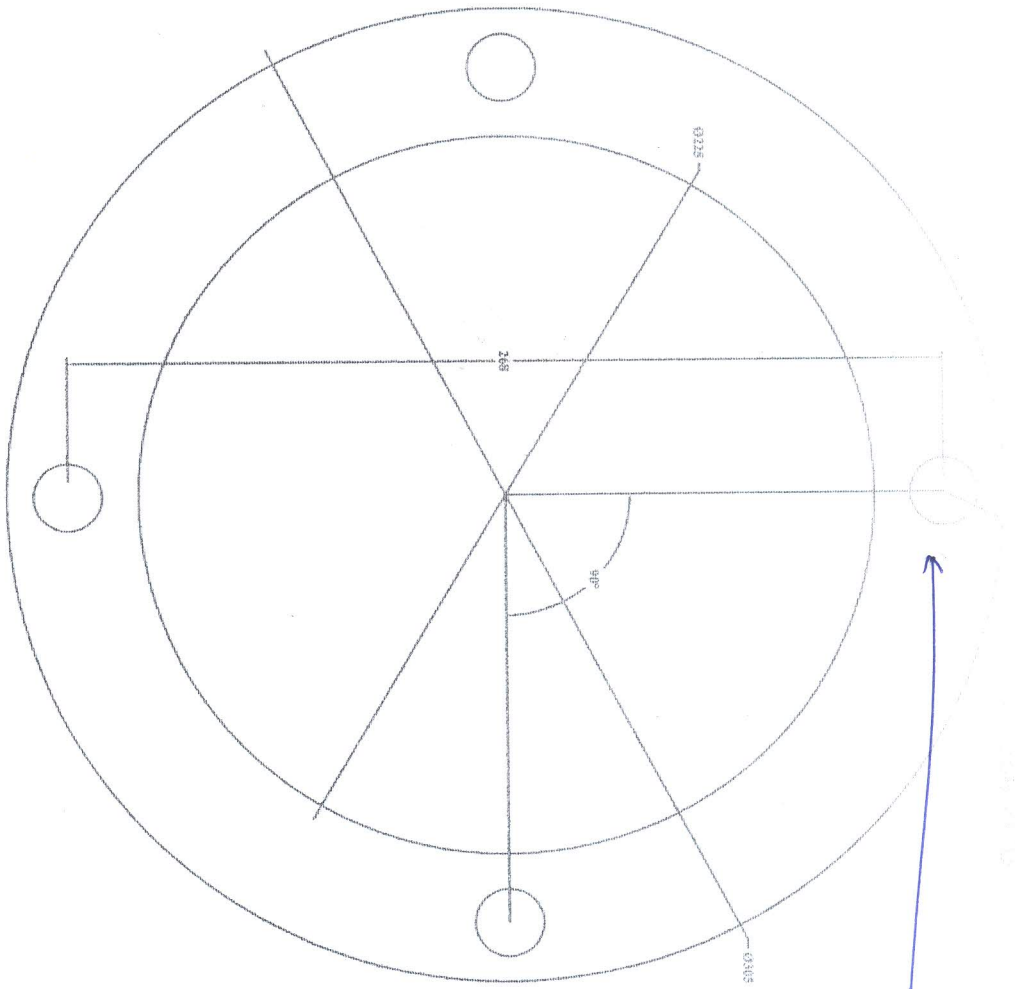

4 Nos, HOLE 21mm
AT 268 PCD

FRONT VIEW



SIDE VIEW

NOTES :- 1. ALL DIMENSIONS ARE IN MM. 2. REMOVE ALL BURRS & SHARP EDGES.		THIS DRAWING IS THE PROPERTY OF INDRAPRASTHA GAS LIMITED . UNAUTHORIZED DISCLOSURE OF ITS CONTENTS AND MANUFACTURE OR SUPPLY OF THE PRODUCT TO ANYONE IS PROHIBITED.		MATERIAL MS SHEET		MS ROUND PLATE FOR INSPECTION PLATE FOR DR COMP.			
OPEN TOLERANCE 0.5-6 ± 0.1 >6-30 ± 0.2		>30-120 ± 0.3 120-315 ± 0.5		NAME K. S. MADHUKAR		DRAWING No. ICI/MIS-123		SCALE NTS.	
REV. NO. REVISION BY DATE		ANGULAR ± 1°		QTY. 01 Nos.		INDRAPRASTHA GAS LTD. NEW DELHI		SHEET 1 OF 1	
DATE 1/1/15		APPD. BY K. S. MADHUKAR		DATE 1/1/15		INDRAPRASTHA GAS LTD. NEW DELHI		SHEET 1 OF 1	

4 Nos, Hole 21mm
AT 268 PCD

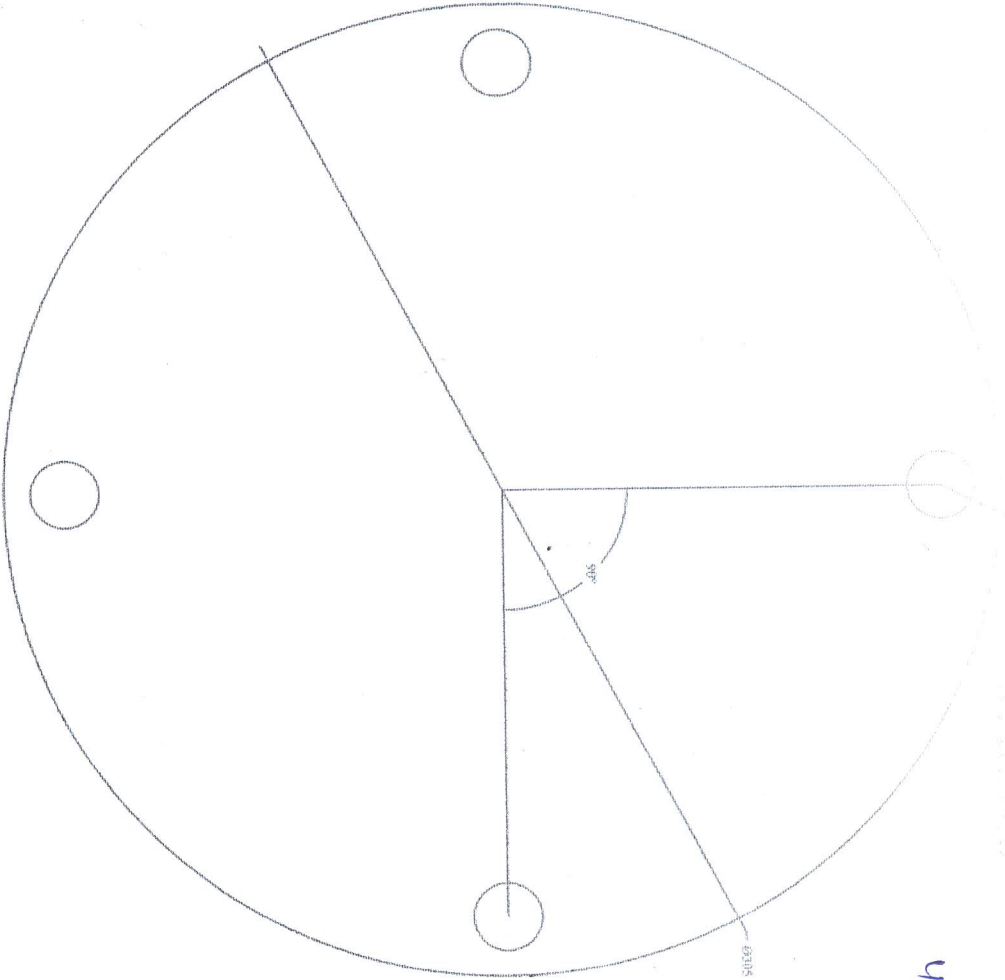

FRONT VIEW



SIDE VIEW

NOTES :-
1. ALL DIMENSIONS ARE IN MM.
2. REMOVE ALL BURS & SHARP EDGES

THIS DRAWING IS THE PROPERTY OF INDRAPRASTHA GAS LIMITED UNAUTHORISED DISCLOSURE OF ITS CONTENTS AND MANUFACTURE OR SUPPLY OF THE PRODUCT TO ANYONE IS PROHIBITED.

MATERIAL
ACRYLIC SHEET

TREATMENT

INSPECTION PLATE FOR
DR COMP.



NAME	SIGN.	DATE
DRW. BY		
CHKD. BY		
APPD. BY		

DRAWING No. ICI/MIS-127

SHEET NTS.

0.5-6	± 0.1	> 30-120	± 0.3
> 6.30	± 0.2	> 120-315	± 0.5

INDRAPRASTHA GAS LTD.
NEW DELHI

SHEET 1 OF 1

REV. NO.	REVISION	BY	DATE

OPEN TOLERANCE	ANGULAR
± 1°	± 1°

QTY.	01 Nos.
------	---------

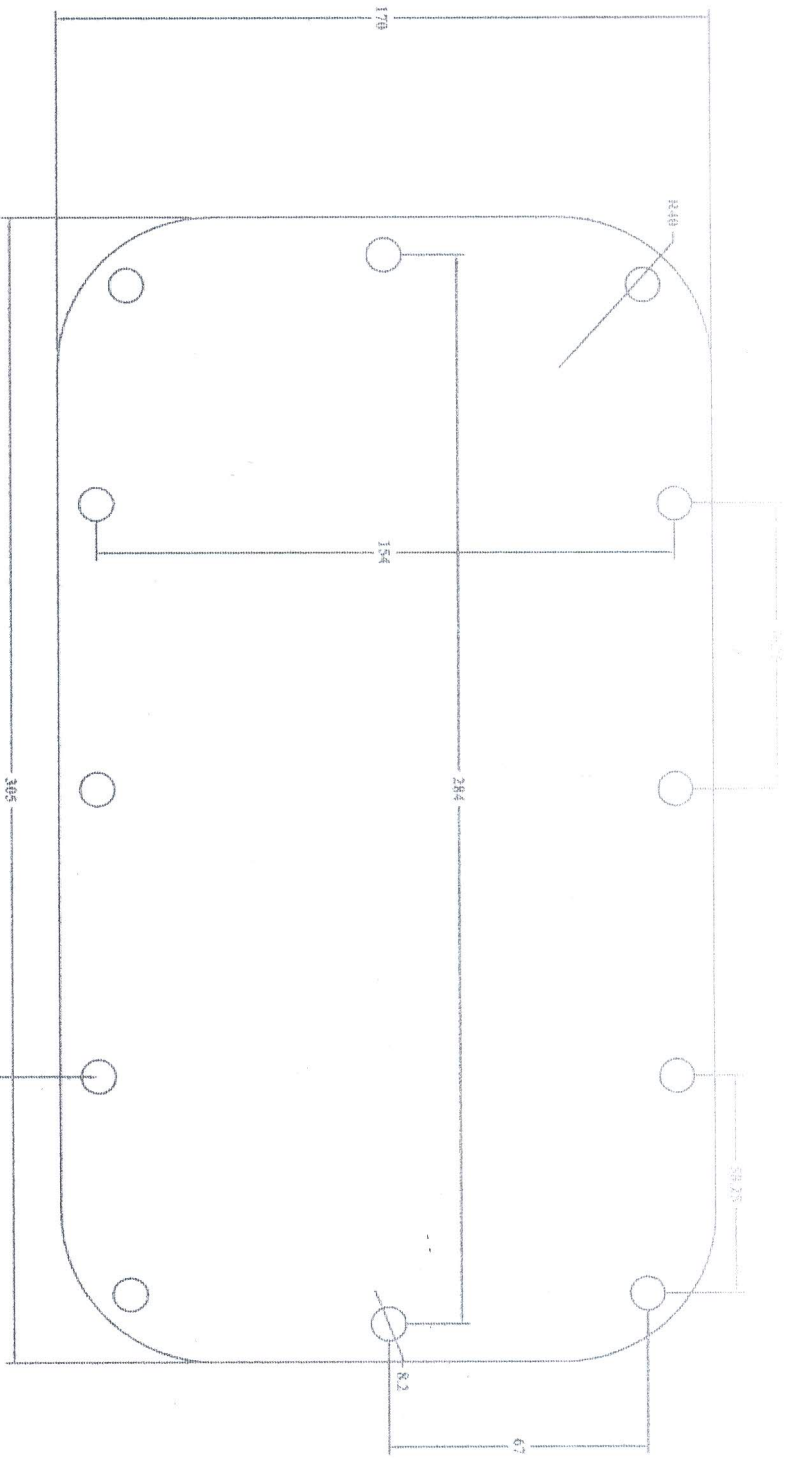

FRONT VIEW

SIDE VIEW

NOTES :-
 1. ALL DIMENSIONS ARE IN MM.
 2. REMOVE ALL BURRS & SHARP EDGES.

THIS DRAWING IS THE PROPERTY OF **INDRAPRASTHA GAS LIMITED**. UNAUTHORISED DISCLOSURE OF ITS CONTENTS AND MANUFACTURE OR SUPPLY OF THE PRODUCT TO ANYONE IS PROHIBITED.

TREATMENT

INSPECTION PLATE OF DELTA 1200 COMP.



OPEN TOLERANCE

NAME	SIGN.	DATE
DRN. BY		
CHKD. BY		
APP'D. BY		

DRAWING No. **IGL/MIS-124**

SCALE

NTS.

INDRAPRASTHA GAS LTD.
 NEW DELHI

SHEET 1 OF 1

REV. NO.	REVISION	BY	DATE	ANGULAR	±
				> 30-120	± 0.1
				> 120-315	± 0.2
				> 315-630	± 0.3
				> 630	± 0.5

QTY.	01 Nos.

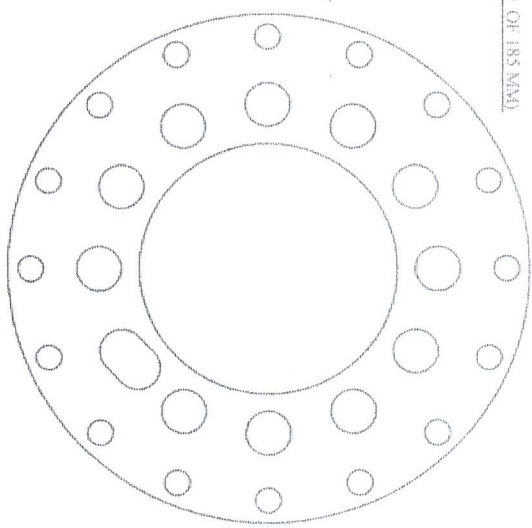
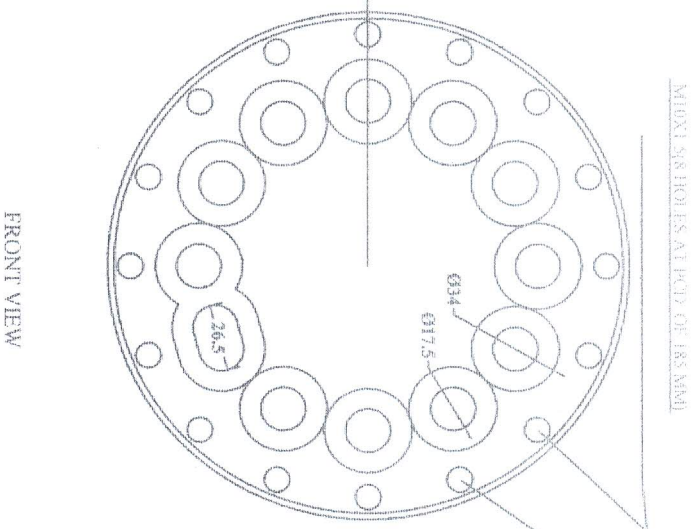
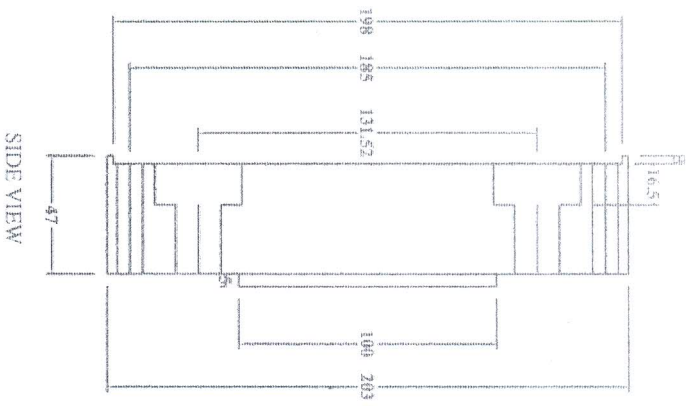

18 HOLES AT PCD OF 185 MM

3/8 BSW
18 HOLES AT PCD OF 185 MM

SIDE VIEW

FRONT VIEW

REAR VIEW

NOTES :-
1. ALL DIMENSIONS ARE IN MM
2. REMOVE ALL BURRS & SHARP EDGES

THIS DRAWING IS THE PROPERTY OF **INDRAPRASTHA GAS LIMITED** UNAUTHORISED DISCLOSURE OF ITS CONTENTS AND MANUFACTURE OR SUPPLY OF THE PRODUCT TO ANYONE IS PROHIBITED.

MATERIAL

Carbon Steel

TREATMENT

**Hub for Delta
(Engine Side)**

NAME SIGN. DATE

DRAWING No. IGL/MIS-118

SCALE

NTS.

OPEN TOLERANCE
0.5-6 ± 0.1 > 30-120 ± 0.3
> 6-30 ± 0.2 > 120-315 ± 0.5

DRW BY: *Kaj Kumar*
CHK BY: *MS*
APPD BY: *MS*
DATE: *11/6/15*

INDRAPRASTHA GAS LTD.
NEW DELHI

SHEET 1 OF 1

REV. No	REVISION	BY	DATE	ANGULAR	± 1°	QTY.	01 Nos.



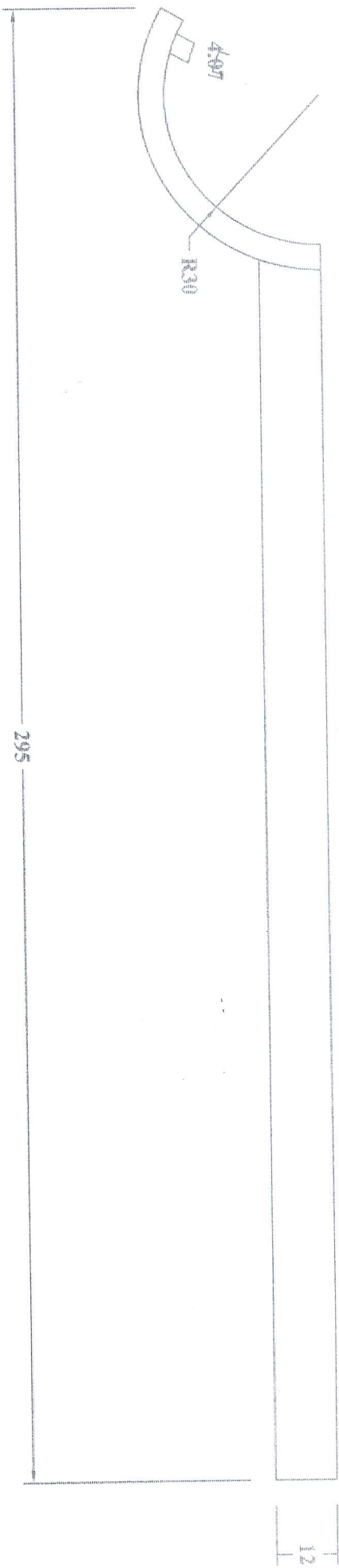

NOTES :-
 1. ALL DIMENSIONS ARE IN MM
 2. REMOVE ALL BURRS & SHARP EDGES.

THIS DRAWING IS THE PROPERTY OF **INDRAPRASTHA GAS LIMITED**. UNAUTHORISED DISCLOSURE OF ITS CONTENTS AND MANUFACTURE OR SUPPLY OF THE PRODUCT TO ANYONE IS PROHIBITED

MATERIAL C STEEL		TREATMENT		DRAWING No. IOL/MIS-119		SCALE NTS.	
NAME <i>Raj Kumar</i>		SIGN. <i>[Signature]</i>		DATE <i>1/6/15</i>		SHEET 1 OF 1	
DRN. BY <i>Raj Kumar</i>		CHD. BY <i>[Signature]</i>		INDRAPRASTHA GAS LTD. NEW DELHI			
APPD. BY <i>[Signature]</i>		QTY.		01 Nos.			
OPEN TOLERANCE							
0.5-6	± 0.1	> 30-120	± 0.3				
> 6-30	± 0.2	> 120-315	± 0.5				
REV. No.	REVISION	BY	DATE	ANGULAR	± I°		

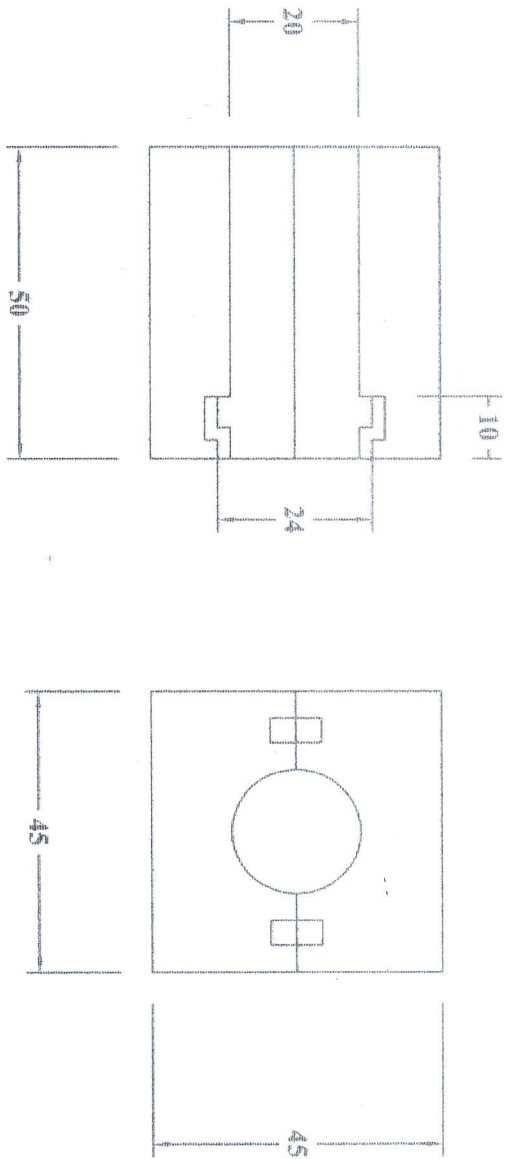

NOTES :-
 1. ALL DIMENTIONS ARE IN MM.
 2. REMOVE ALL BURRS & SHARP EDGES

THIS DRAWING IS THE PROPERTY OF **INDRAPRASTHA GAS LIMITED**. UNAUTHORISED DISCLOSURE OF ITS CONTENTS AND MANUFACTURE OR SUPPLY OF THE PRODUCT TO ANYONE IS PROHIBITED.

MATERIAL
C STEEL

TREATMENT

Car Nozal Repairing Arrangement

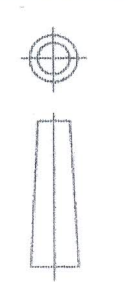

OPEN TOLERANCE		NAME		SIGN.		DATE	
0.5-6	± 0.1	>30-120	± 0.3	DRN By		1/11/15	
	± 0.1		± 0.3	CHD By		Raj Kumar	
>6-30	± 0.2	>120-315	± 0.5	APPD By		D.S.	
REV. No	REVISION	BY	DATE	ANGULAR	± T	QTY.	01 Nos.
DRAWING No. IGI/MIS-120				SCALE			
INDRAPRASTHA GAS LTD.				NTS.			
NEW DELHI				SHEET			
				1 OF 1			

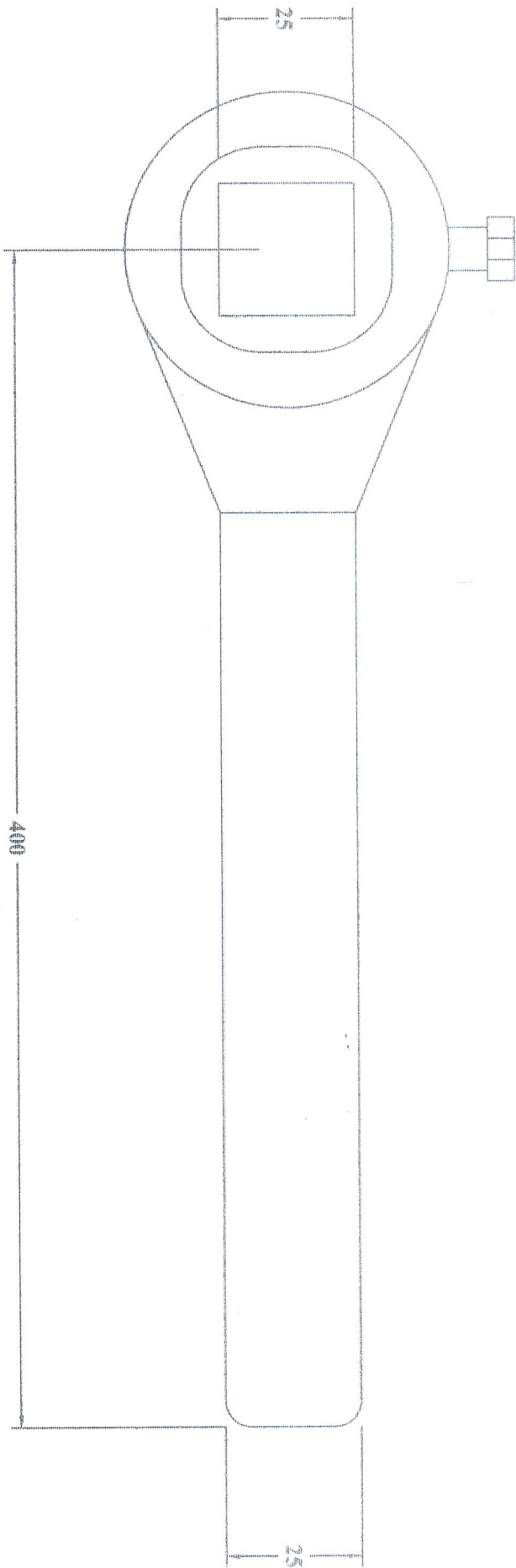

NOTES :-
 1. ALL DIMENTIONS ARE IN MM.
 2. REMOVE ALL BURRS & SHARP EDGES.

THIS DRAWING IS THE PROPERTY OF **INDRAPRASTHA GAS LIMITED**. UNAUTHORISED DISCLOSURE OF ITS CONTENTS AND MANUFACTURE OR SUPPLY OF THE PRODUCT TO ANYONE IS PROHIBITED.

MATERIAL: **C STEEL**

TREATMENT:

Handle for Isolation Valve

OPEN TOLERANCE		DRAWN BY		NAME		SIGN.		DATE		DRAWING NO. IGI./MIS-121		SCALE	
0.5-6	± 0.1	> 30-120	± 0.3	DRN. BY						INDRAPRASTHA GAS LTD.		SHEET	
> 6-30	± 0.2	> 120-315	± 0.5	CHKD. BY	Ko. Kumar			1/6/15		NEW DELHI		1 OF 1	
ANGULAR	± 1'	QTY	01 Nos.	APPD. BY									
REVISION	BY	DATE											

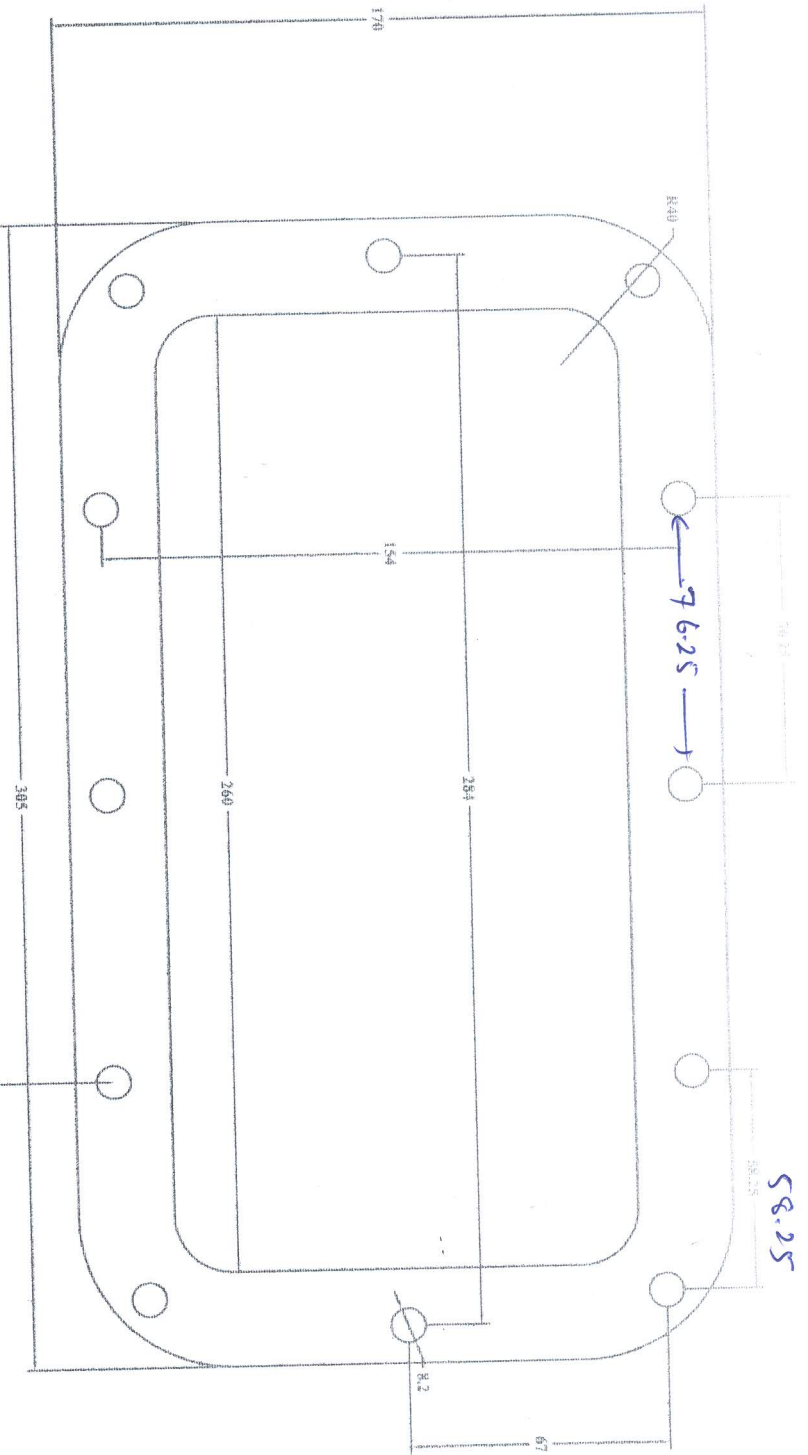

FRONT VIEW

SIDE VIEW

NOTES :-
 1. ALL DIMENSIONS ARE IN MM.
 2. REMOVE ALL BURRS & SHARP EDGES.

THIS DRAWING IS THE PROPERTY OF **INDRAPASTHA GAS LIMITED** UNAUTHORIZED DISCLOSURE OF ITS CONTENTS AND MANUFACTURE OR SUPPLY OF THE PRODUCT TO ANYONE IS PROHIBITED.

MATERIAL: **MS SHEET**

TREATMENT:

MS RECTANGULAR PLATE FOR INSPECTION PLATE OF DELTA 1200 COMP.

NAME	SIGN.	DATE

DRAWING No. **IGI/MIS-122**

SCALE: **NTS.**



OPEN TOLERANCE	DRN/By	CHKD/By	APPD/By
0.5-6 ± 0.1			
> 30-120 ± 0.3			
> 6-30 ± 0.2			
> 120-315 ± 0.5			

INDRAPASTHA GAS LTD. NEW DELHI

SHEET **1 OF 1**

REV. No

REVISION

BY

DATE

ANGULAR ± 1°

QTY. 01 Nos.

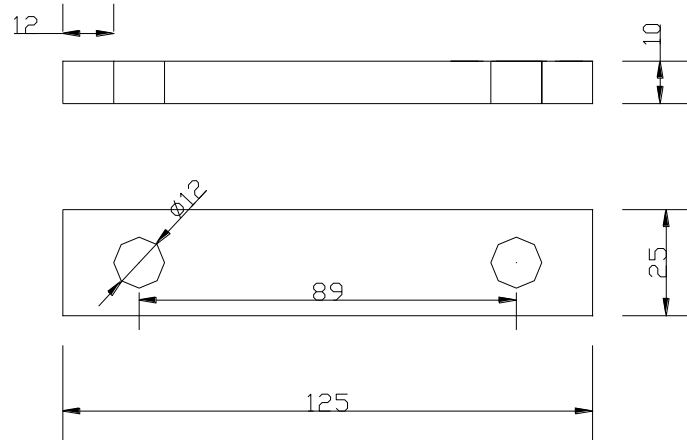

NOTES :-
 1. ALL DIMENSIONS ARE IN MM.
 2. REMOVE ALL BURRS & SHARP EDGES.

THIS DRAWING IS THE PROPERTY OF **INDRAPRASTHA GAS LIMITED**. UNAUTHORISED DISCLOSURE OF ITS CONTENTS AND MANUFACTURE OR SUPPLY OF THE PRODUCT TO ANYONE IS PROHIBITED.

MATERIAL

Alluminium Solid

Aluminium Spacer for Cooler (DELTA)

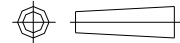

TREATMENT

DRAWING No.

SCALE

NTS.

OPEN TOLERANCE

0.5-6	± 0.1	>30-120	± 0.3
>6-30	± 0.2	>120-315	± 0.5

DRN.By

NAME

SIGN.

DATE

CHD.By

APPD.By

INDRAPRASTHA GAS LTD.
NEW DELHI

SHEET

1 OF 1

REV.No. REVISION BY DATE

ANGULAR ± 1°

QTY.

01 Nos.

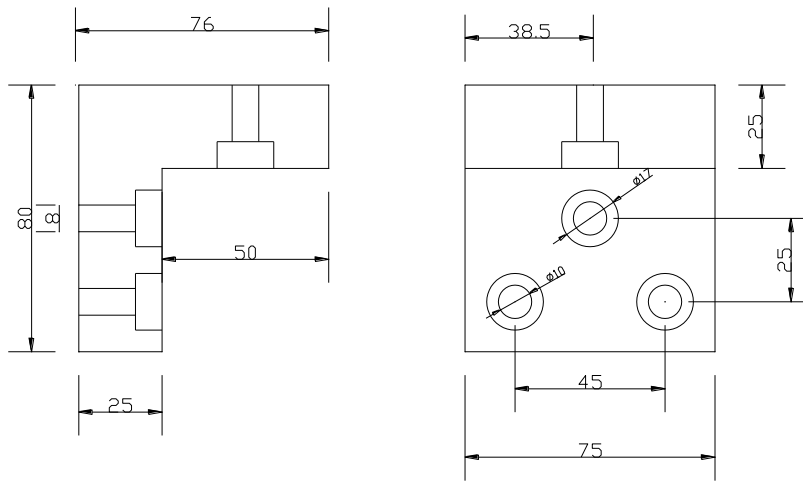

NOTES :- 1. ALL DIMENSIONS ARE IN MM. 2. REMOVE ALL BURRS & SHARP EDGES.				THIS DRAWING IS THE PROPERTY OF INDRAPRASTHA GAS LIMITED. UNAUTHORISED DISCLOSURE OF ITS CONTENTS AND MANUFACTURE OR SUPPLY OF THE PRODUCT TO ANYONE IS PROHIBITED.				MATERIAL Aluminium Cast				Aluminium Mounting Bracket for High mast													
				TREATMENT								DRAWING No.				SCALE NTS.									
				OPEN TOLERANCE				NAME				SIGN.				DATE									
				0.5-6 ± 0.1 >30-120 ± 0.3				DRN.By																	
				>6-30 ± 0.2 >120-315 ± 0.5				CHD.By																	
				ANGULAR ± 1°				APPD.By																	
REV.No				REVISION				BY				DATE				QTY.				01 Nos.					
												INDRAPRASTHA GAS LTD. NEW DELHI												SHEET 1 OF 1	

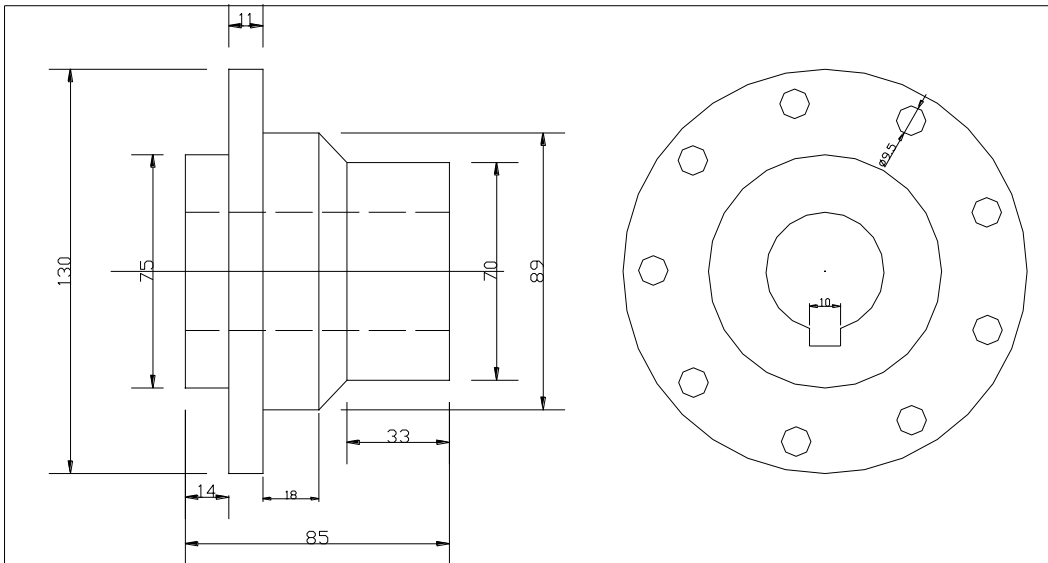

NOTES :- 1. ALL DIMENSIONS ARE IN MM. 2. REMOVE ALL BURRS & SHARP EDGES.				THIS DRAWING IS THE PROPERTY OF INDRAPRASTHA GAS LIMITED. UNAUTHORISED DISCLOSURE OF ITS CONTENTS AND MANUFACTURE OR SUPPLY OF THE PRODUCT TO ANYONE IS PROHIBITED.				MATERIAL Alluminium Solid			Aluminium Hub for Fan (DELTA)		
								TREATMENT			DRAWING No.		
				OPEN TOLERANCE		NAME SIGN. DATE			DRN.By		INDRAPRASTHA GAS LTD. NEW DELHI	SHEET 1 OF 1	
				0.5-6 ± 0.1 >30-120 ± 0.3		CHD.By			CHD.By				
REV.No REVISION BY DATE				>6-30 ± 0.2 >120-315 ± 0.5		APPD.By			APPD.By				
				ANGULAR ± 1°		QTY.			01 Nos.				

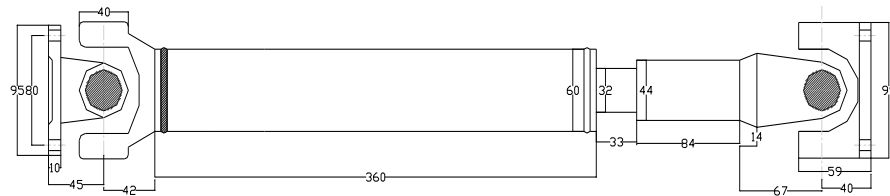

NOTES :- 1. ALL DIMENTIONS ARE IN MM. 2. REMOVE ALL BURRS & SHARP EDGES.				THIS DRAWING IS THE PROPERTY OF INDRAPRASTHA GAS LIMITED . UNAUTHORISED DISCLOSURE OF ITS CONTENTS AND MANUFACTURE OR SUPPLY OF THE PRODUCT TO ANYONE IS PROHIBITED.				MATERIAL EN 36				UNIVERSAL SHAFT(Fan) for DELTA 600 COMP. PACKAGE			
								TREATMENT							
				OPEN TOLERANCE				NAME SIGN. DATE		INDRAPRASTHA GAS LTD. NEW DELHI		SHEET 1 OF 1			
				0.5-6 ± 0.1 >30-120 ± 0.3				DRN.By							
				>6-30 ± 0.2 >120-315 ± 0.5				CHD.By							
REV.No. REVISION BY DATE				ANGULAR ± 1°				APPD.By							
				QTY. 01 Nos.											

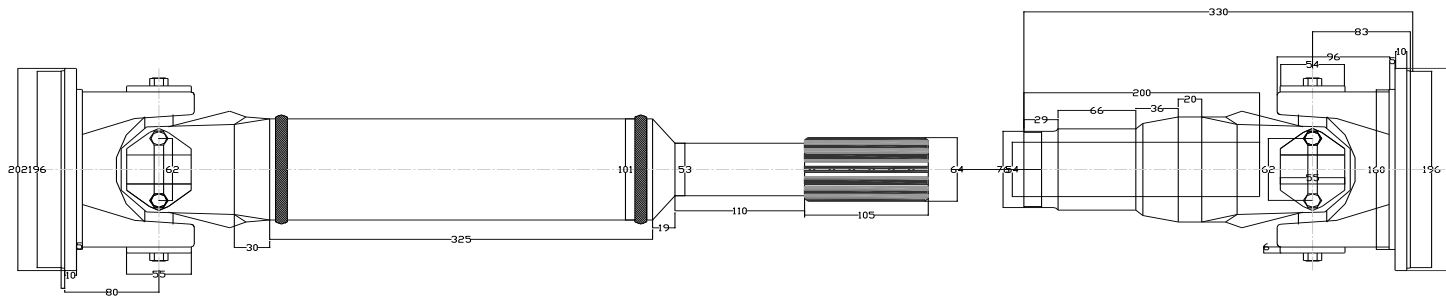

NOTES :- 1. ALL DIMENSIONS ARE IN MM. 2. REMOVE ALL BURRS & SHARP EDGES.				THIS DRAWING IS THE PROPERTY OF INDRAPRASTHA GAS LIMITED . UNAUTHORISED DISCLOSURE OF ITS CONTENTS AND MANUFACTURE OR SUPPLY OF THE PRODUCT TO ANYONE IS PROHIBITED.				MATERIAL EN 36				UNIVERSAL SHAFT(Main) for DELTA 600 COMP. PACKAGE			
								TREATMENT						NAME	
				OPEN TOLERANCE				<i>DRN.By</i>				INDRAPRASTHA GAS LTD. NEW DELHI		SHEET 1 OF 1	
				0.5-6 ± 0.1 >30-120 ± 0.3				<i>CHD.By</i>							
				>6-30 ± 0.2 >120-315 ± 0.5				<i>APPD.By</i>							
REV.No				REVISION				BY		DATE		ANGULAR ± 1°		<i>QTY.</i> 01 Nos.	

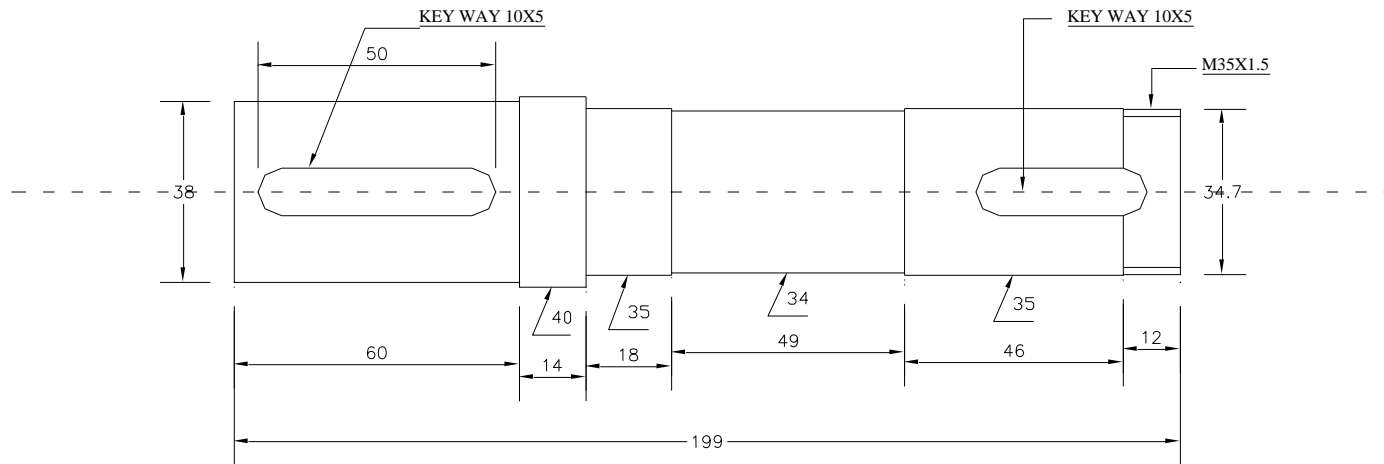

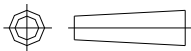
NOTES :- 1. ALL DIMENSIONS ARE IN MM. 2. REMOVE ALL BURRS & SHARP EDGES.				THIS DRAWING IS THE PROPERTY OF INDRAPRASTHA GAS LIMITED. UNAUTHORISED DISCLOSURE OF ITS CONTENTS AND MANUFACTURE OR SUPPLY OF THE PRODUCT TO ANYONE IS PROHIBITED.				MATERIAL EN 8			DRIVEN SHAFT FOR GEAR BOX (DELTA)		
								TREATMENT					
							NAME	SIGN.	DATE	DRAWING No.		SCALE	
				OPEN TOLERANCE 0.5-6 ± 0.1 >30-120 ± 0.3 >6-30 ± 0.2 >120-315 ± 0.5			DRN.By			INDRAPRASTHA GAS LTD. NEW DELHI		SHEET 1 OF 1	
REV.No.	REVISION	BY	DATE	ANGULAR ± 1°			CHD.By						
							APPD.By						
							QTY.	01 Nos.					

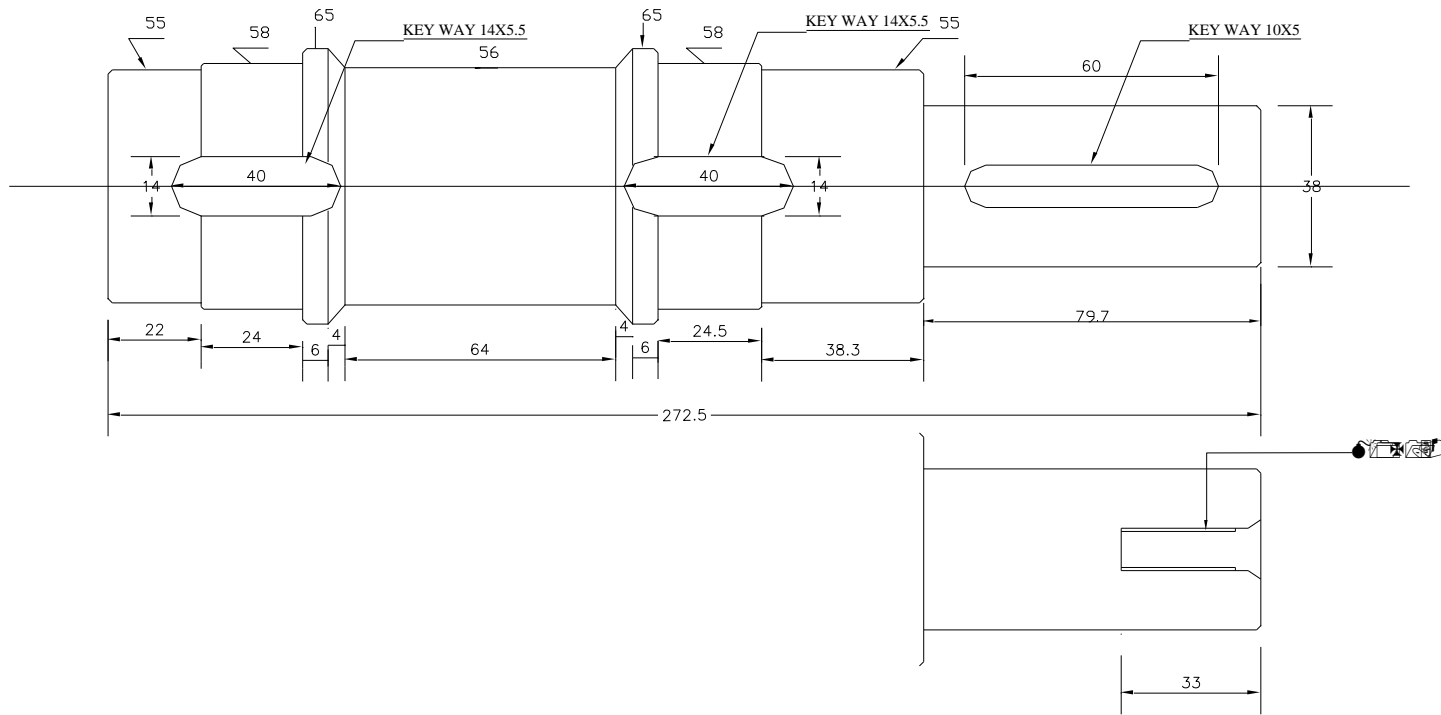

NOTES :-
 1. ALL DIMENSIONS ARE IN MM.
 2. REMOVE ALL BURRS & SHARP EDGES.

THIS DRAWING IS THE PROPERTY OF **INDRAPRASTHA GAS LIMITED**. UNAUTHORISED DISCLOSURE OF ITS CONTENTS AND MANUFACTURE OR SUPPLY OF THE PRODUCT TO ANYONE IS PROHIBITED.

MATERIAL

EN 8

TREATMENT

DRIVER SHAFT FOR GEAR BOX (DELTA)

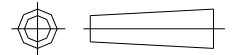

NAME	SIGN.	DATE

DRAWING No.

SCALE
NTS.

OPEN TOLERANCE

0.5-6	± 0.1	>30-120	± 0.3
-------	-------	---------	-------

>6-30	± 0.2	>120-315	± 0.5
-------	-------	----------	-------

DRN.By

CHD.By

APPD.By

INDRAPRASTHA GAS LTD.
NEW DELHI

SHEET
1 OF 1

REV.No.	REVISION	BY	DATE

ANGULAR ± 1°

QTY. 01 Nos.

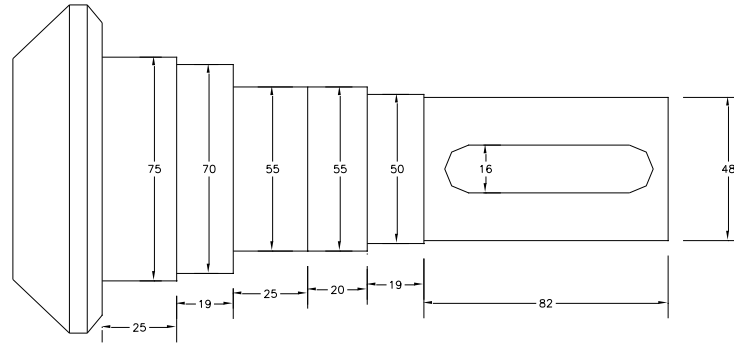
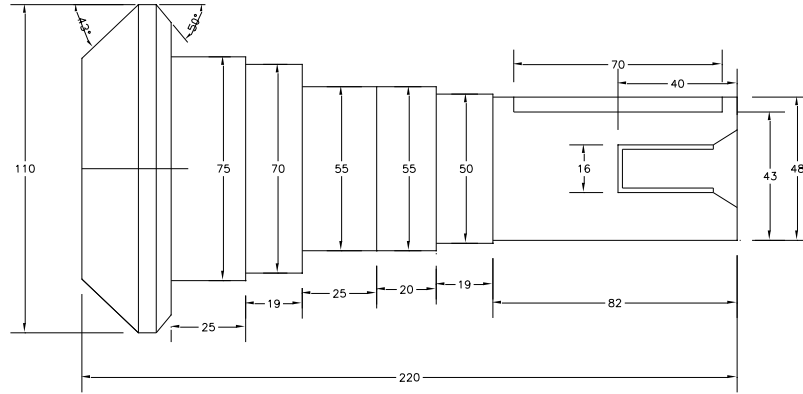
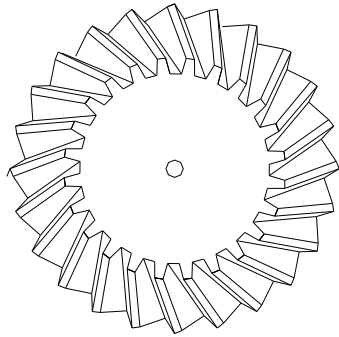

NOTES :- 1. ALL DIMENTIONS ARE IN MM. 2. REMOVEL ALL BURRS & SHARP EDGES.				THIS DRAWING IS THE PROPERTY OF INDRAPRASTHA GAS LIMITED. UNAUTHORISED DISCLOSURE OF ITS CONTENTS AND MANUFACTURE OR SUPPLY OF THE PRODUCT TO ANYONE IS PROHIBITED.				MATERIAL EN 36			DRIVEN SHAFT FOR GEAR BOX (DR)			
								TREATMENT						
				OPEN TOLERANCE			NAME SIGN. DATE			DRAWING No.		SCALE NTS.		
				0.5-6 ± 0.1 >30-120 ± 0.3			DRN.By			INDRAPRASTHA GAS LTD. NEW DELHI		SHEET 1 OF 1		
				>6-30 ± 0.2 >120-315 ± 0.5			CHD.By							
REV.No	REVISION	BY	DATE	ANGULAR ± 1°			APPD.By							
				QTY.			01 Nos.							

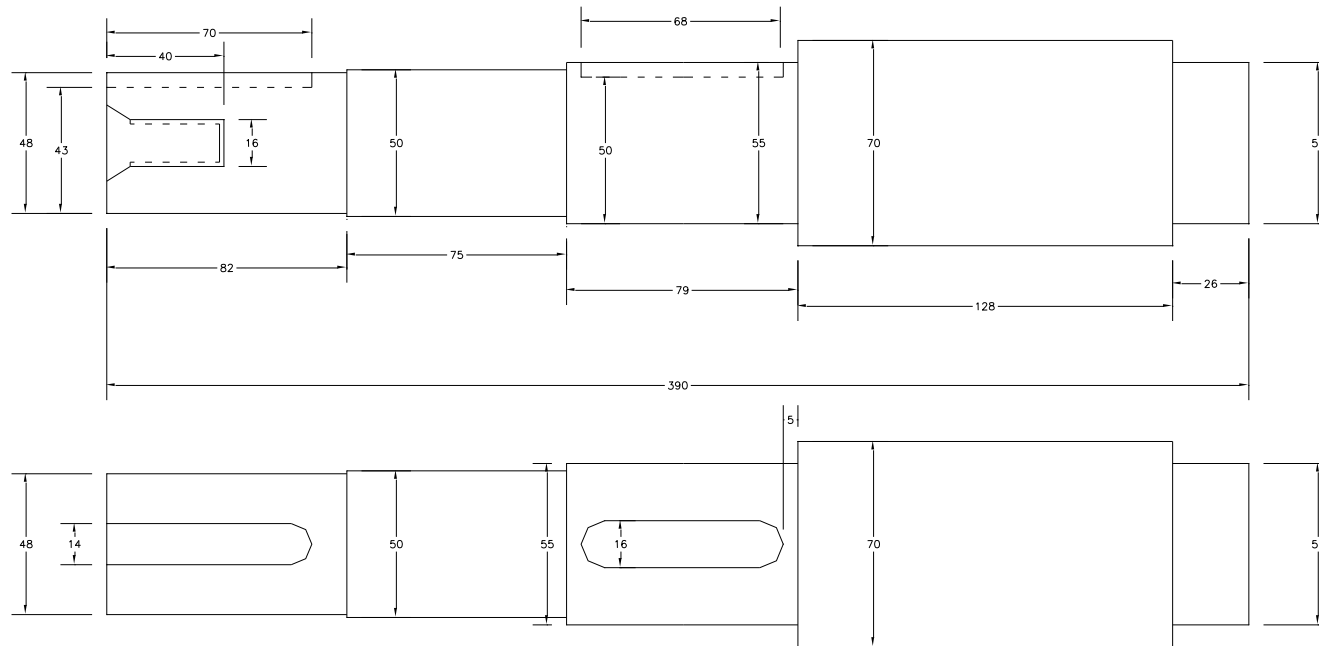

NOTES :- 1. ALL DIMENSIONS ARE IN MM. 2. REMOVE ALL BURRS & SHARP EDGES.				THIS DRAWING IS THE PROPERTY OF INDRAPRASTHA GAS LIMITED . UNAUTHORISED DISCLOSURE OF ITS CONTENTS AND MANUFACTURE OR SUPPLY OF THE PRODUCT TO ANYONE IS PROHIBITED.				MATERIAL EN 8			DRIVER SHAFT FOR GEAR BOX (DR)		
								TREATMENT					
OPEN TOLERANCE				NAME SIGN. DATE			INDRAPRASTHA GAS LTD. NEW DELHI		SCALE NTS.				
0.5-6 ± 0.1 >30-120 ± 0.3				DRN.By					SHEET 1 OF 1				
>6-30 ± 0.2 >120-315 ± 0.5				CHD.By									
REV.No REVISION BY DATE				APPD.By									
ANGULAR ± 1°				QTY.			01 Nos.						

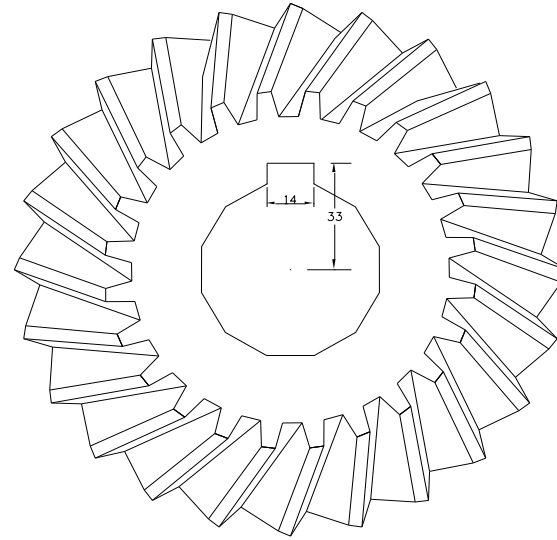
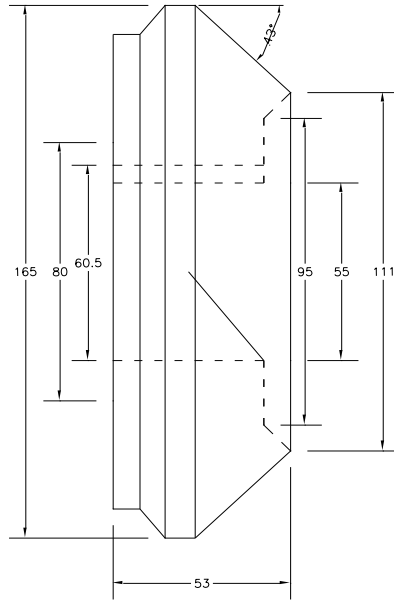

NOTES :-

1. ALL DIMENSIONS ARE IN MM.
2. REMOVE ALL BURRS & SHARP EDGES.

THIS DRAWING IS THE PROPERTY OF **INDRAPRASTHA GAS LIMITED**. UNAUTHORISED DISCLOSURE OF ITS CONTENTS AND MANUFACTURE OR SUPPLY OF THE PRODUCT TO ANYONE IS PROHIBITED.

MATERIAL

EN 36

TREATMENT

DRIVE GEAR FOR DR GEAR BOX

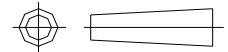

NAME	SIGN.	DATE

DRAWING No.

SCALE
NTS.

OPEN TOLERANCE

0.5-6	± 0.1	>30-120	± 0.3
-------	-------	---------	-------

>6-30	± 0.2	>120-315	± 0.5
-------	-------	----------	-------

DRN.By

CHD.By

APPD.By

INDRAPRASTHA GAS LTD.
NEW DELHI

SHEET
1 OF 1

REV.No.	REVISION	BY	DATE

ANGULAR ± 1°

QTY. 01 Nos.

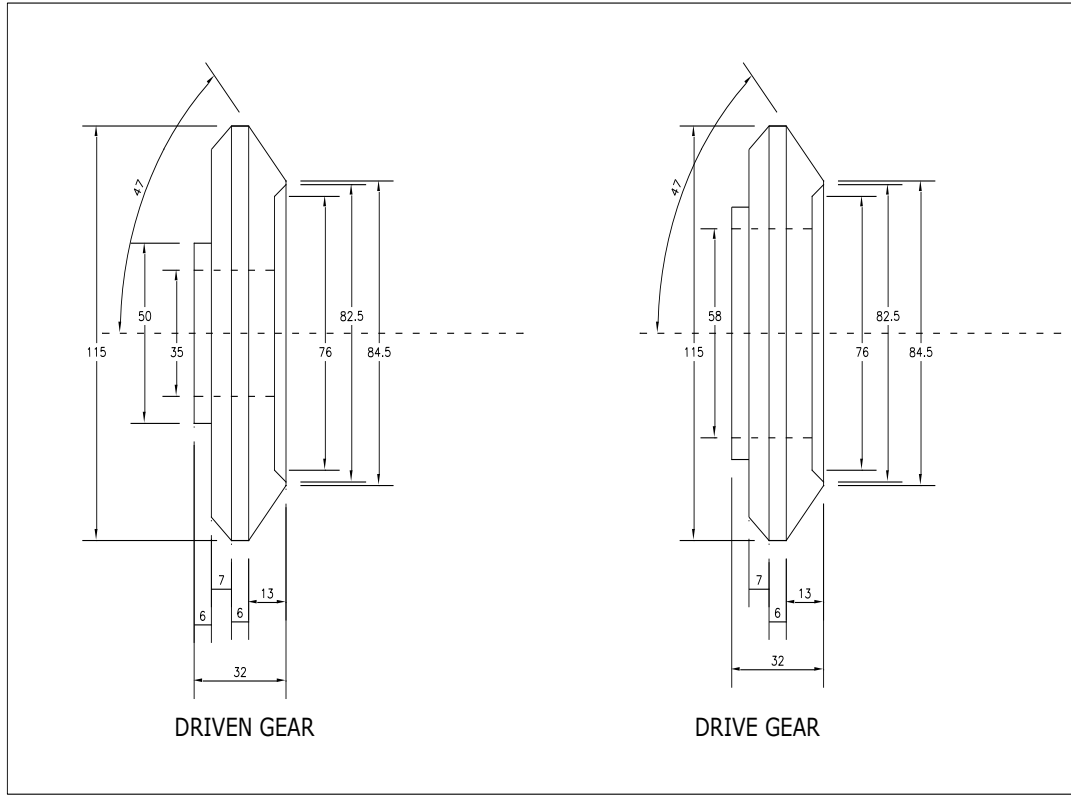

NOTES :- 1. ALL DIMENTIONS ARE IN MM. 2. REMOVE ALL BURRS & SHARP EDGES.		THIS DRAWING IS THE PROPERTY OF INDRAPRASTHA GAS LIMITED . UNAUTHORISED DISCLOSURE OF ITS CONTENTS AND MANUFACTURE OR SUPPLY OF THE PRODUCT TO ANYONE IS PROHIBITED.		MATERIAL EN 36			GEAR FOR DELTA GEAR BOX	
				TREATMENT				
				NAME SIGN. DATE	DRAWING No.		SCALE NTS.	
		OPEN TOLERANCE		DRN.By CHD.By APPD.By	INDRAPRASTHA GAS LTD. NEW DELHI		SHEET 1 OF 1	
REV.No. REVISION BY DATE	ANGLAR $\pm 1^\circ$			QTY. 01 Nos.				

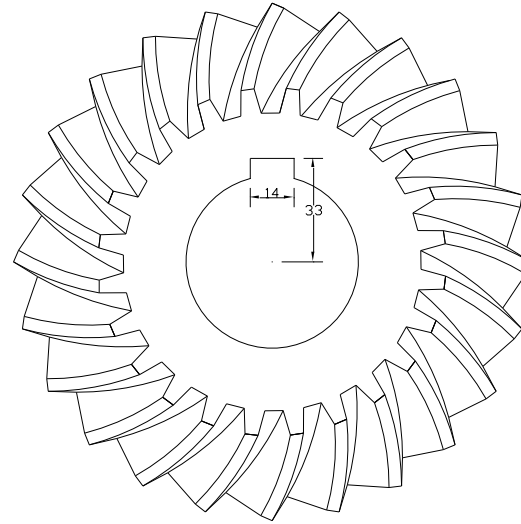
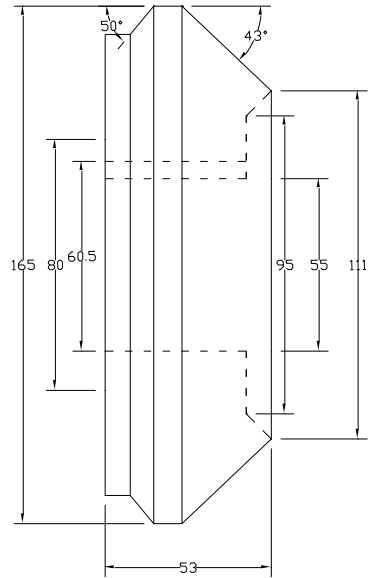

NOTES :-
 1. ALL DIMENTIONS ARE IN MM.
 2. REMOVEL ALL BURRS & SHARP EDGES.

THIS DRAWING IS THE PROPERTY OF **INDRAPRASTHA GAS LIMITED**. UNAUTHORISED DISCLOSURE OF ITS CONTENTS AND MANUFACTURE OR SUPPLY OF THE PRODUCT TO ANYONE IS PROHIBITED.

MATERIAL
 EN 36

TREATMENT

DRIVE GEAR FOR DR GEAR BOX

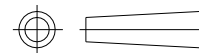

REV.No.	REVISION	BY	DATE	ANGULAR	TOLERANCE	DRN.By	NAME	SIGN.	DATE	QTY.
					OPEN TOLERANCE					
					0.5-6 ± 0.1	>30-120 ± 0.3				
					>6-30 ± 0.2	>120-315 ± 0.5				
					± 1°					01 Nos.

DRAWING No.

INDRAPRASTHA GAS LTD.
NEW DELHI

SCALE
NTS.

SHEET
1 OF 1

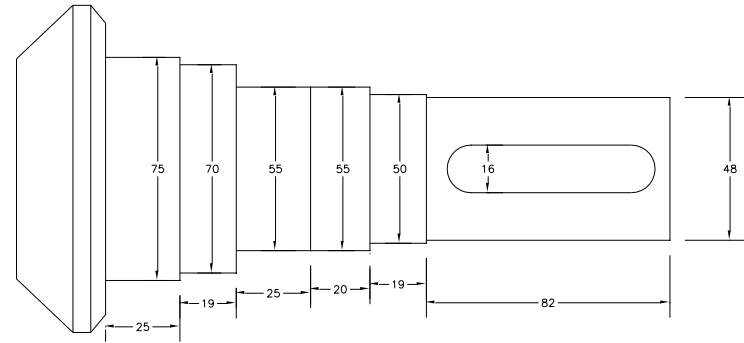
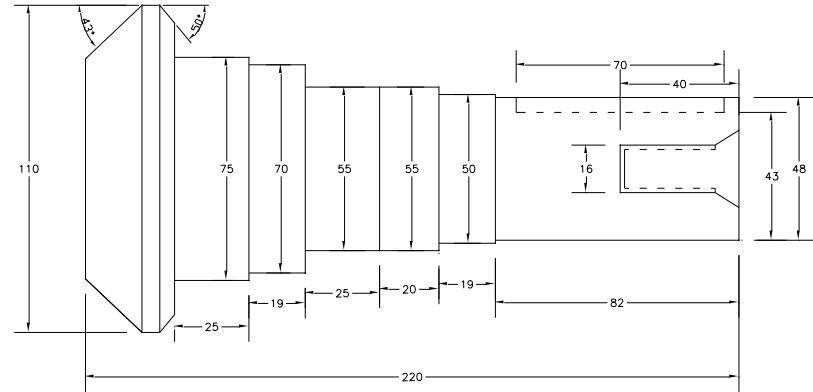
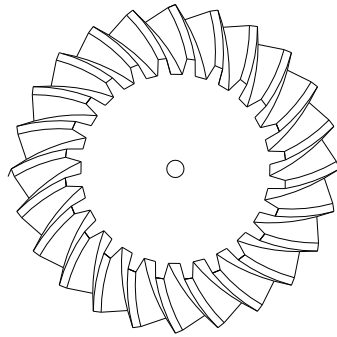

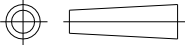
NOTES :- 1. ALL DIMENSIONS ARE IN MM. 2. REMOVE ALL BURRS & SHARP EDGES.				THIS DRAWING IS THE PROPERTY OF INDRAPRASTHA GAS LIMITED . UNAUTHORISED DISCLOSURE OF ITS CONTENTS AND MANUFACTURE OR SUPPLY OF THE PRODUCT TO ANYONE IS PROHIBITED.				MATERIAL EN 36			DRIVEN SHAFT FOR GEAR BOX (DR)			
								TREATMENT						
				OPEN TOLERANCE			NAME SIGN. DATE			DRAWING No.		SCALE NTS.		
				0.5-6 ± 0.1 >30-120 ± 0.3			DRN.By			INDRAPRASTHA GAS LTD. NEW DELHI		SHEET 1 OF 1		
				>6-30 ± 0.2 >120-315 ± 0.5			CHD.By							
REV.No.	REVISION	BY	DATE	ANGULAR ± 1°			APPD.By							
							QTY. 01 Nos.							